

Eaves Box End And Decorative Bargeboard

Box End Detail 4

This detail shows Mammoth Board fascia, bargeboard, and box end cut from a section of fascia.



The box end is usually deeper than the normal fascia run, because of this we offer our 454mm Universal and 404mm Mammoth boards in 1.2 mtr lengths.

Use corner joints at the front of the box end, a Board End Moulding to finish the rear edge of the box end, and an In-Line Joint between the bargeboard and the box end section.

Close the back of the box with a section of fascia (if this is deeper than the fascia, use the material supplied for the box end section) this should be slightly deeper than the measured height so that there is no gap between it and the bargeboard soffit.

Box End Detail 5

This detail shows the bargeboard extending to meet the fascia.



A triangular fillet cut from a suitable piece of **FloPlast** board is set above the bargeboard, and fixed with FloTop nails to the tilt fillet on the gable rafter, another fillet, with either the return leg intact or removed, is fixed with FloTop nails to timber framing supported by the gable ladder, if the return leg is removed the bottom cut edge is protected by attaching a Board End Moulding.

The triangular off cuts may be closely butt jointed and finished with low modulus silicone to the top and bottom edges of the bargeboard.

Use corner joints at the front and the back of the box end cut to suit.

Close the back of the box with a section of fascia (if this is deeper than the fascia, use the material supplied for the box end section) this should be slightly deeper than the measured height so that there is no gap between it and the bargeboard soffit.

FloPlast Decorative Bargeboard Moulding

The **FloPlast** Decorative Bargeboard Moulding offers style and character to most roofline installations. Once installed, it will require very little maintenance, as it will not rot, warp or require painting.



A variety of patterns can be achieved at the bargeboard apex, and two suggested examples are shown below.

A finial joint is now available to add that extra touch of elegance to your home.

Decorative Moulding Installation



Measure the length of your bargeboard and calculate how many mouldings are required at 500mm per moulding, making an allowance for design and plumb cuts at the ridge and barge ends.

Cut to size and screw using four 15mm x 6 self tapping screws, to the underside of the existing **FloPlast** PVC-UE bargeboard. Seal the joint between the moulding and bargeboard with either a low modulus silicone, or an appropriate adhesive.



Box End Detail 4a

Mammoth/Universal Board with a square cut end, fixed directly to the gable rafter

In-Line Joint

External Corner Joint

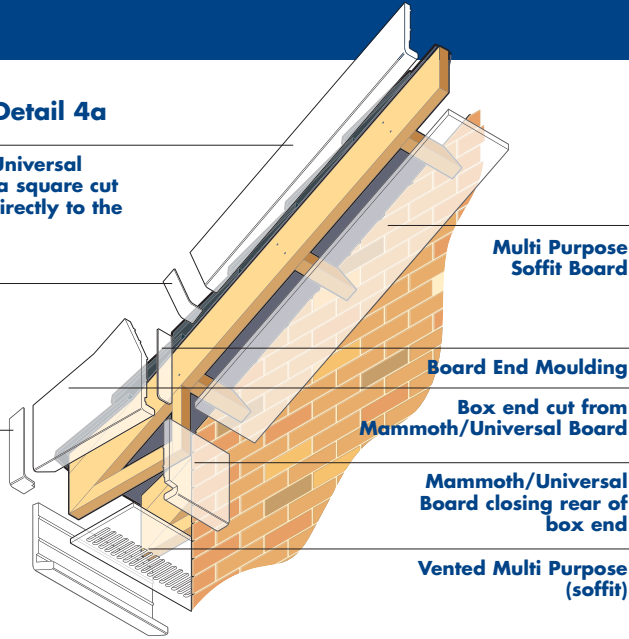

Multi Purpose Soffit Board

Board End Moulding

Box end cut from Mammoth/Universal Board

Mammoth/Universal Board closing rear of box end

Vented Multi Purpose (soffit)

4b

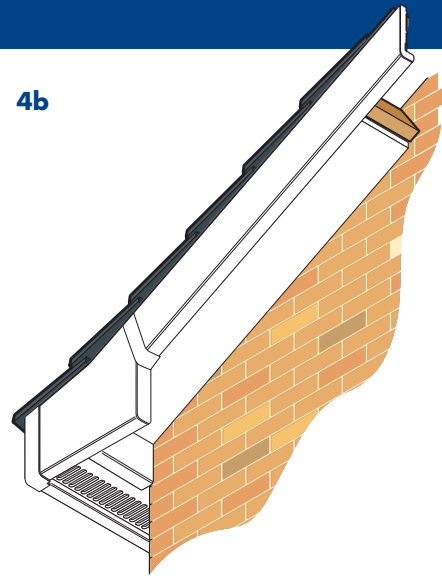

Box End Detail 5a

Mammoth/Universal Board with a vertical cut end, fixed directly to the gable rafter

External Corner Joint

Fillets cut from a suitable piece of FloPlast board

External Corner Joint

Alternative Board End Moulding

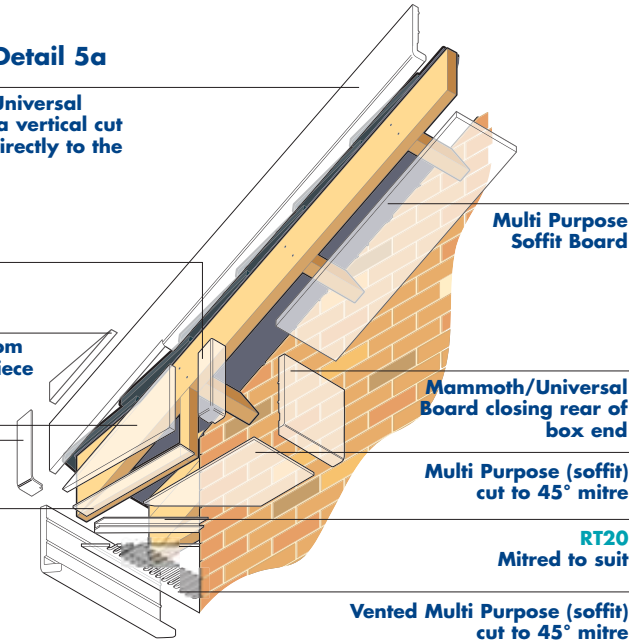

Multi Purpose Soffit Board

Mammoth/Universal Board closing rear of box end

Multi Purpose (soffit) cut to 45° mitre

RT20 Mitred to suit

Vented Multi Purpose (soffit) cut to 45° mitre

5b

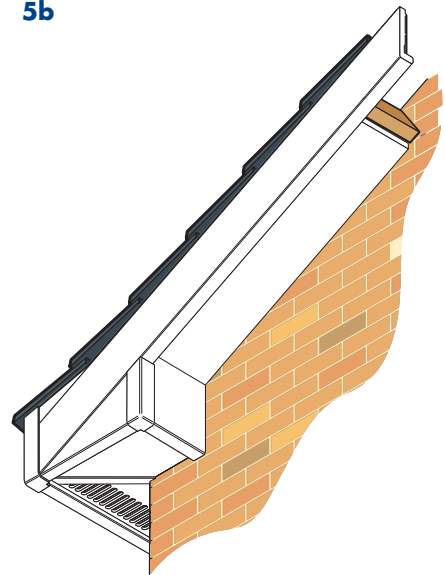

Decorative Bargeboard Moulding

