

# Marketing Bulletin

November 2008

## New regulations for paving over gardens

From 1st October 2008, planning permission will be required for all house owners wishing to pave over their gardens.

The reasons behind implementing this new regulation is largely due to climate change. In 2007, serious floods caused mass disruption which included major problems with drainage systems. Flooding contributed to drains not having capacity to cope with the amount of rainwater running through them. It is highly likely that flooding on this scale will happen again in the not so distant future. Combined with the building of new developments, paving of front gardens will mean drains taking increasing amounts of water. Studies show that hard surfaces can increase surface water by up to 50%, therefore putting more strain on our drainage systems.

New regulations state if the surface of a garden to be covered is more than five square metres, planning permission must be obtained. This is essential when laying traditional and impermeable driveways which cannot control rainwater running off onto roads.

Permission will also incur an additional charge and a wait of up to 8 weeks.

**One of the solutions accepted will be to install channel drainage. FloPlast provides a domestic surface channel drainage system called FloDrain, designed to tackle this growing problem.**

- Quality domestic surface Channel Drainage 110mm x 100mm
- Anti-slip heel guard grating
- 5 tonne spread load 1.5 tonne point load
- 4 outlets per length for maximum flexibility
- Quad section for corners and junctions
- Concave grid for maximum flow

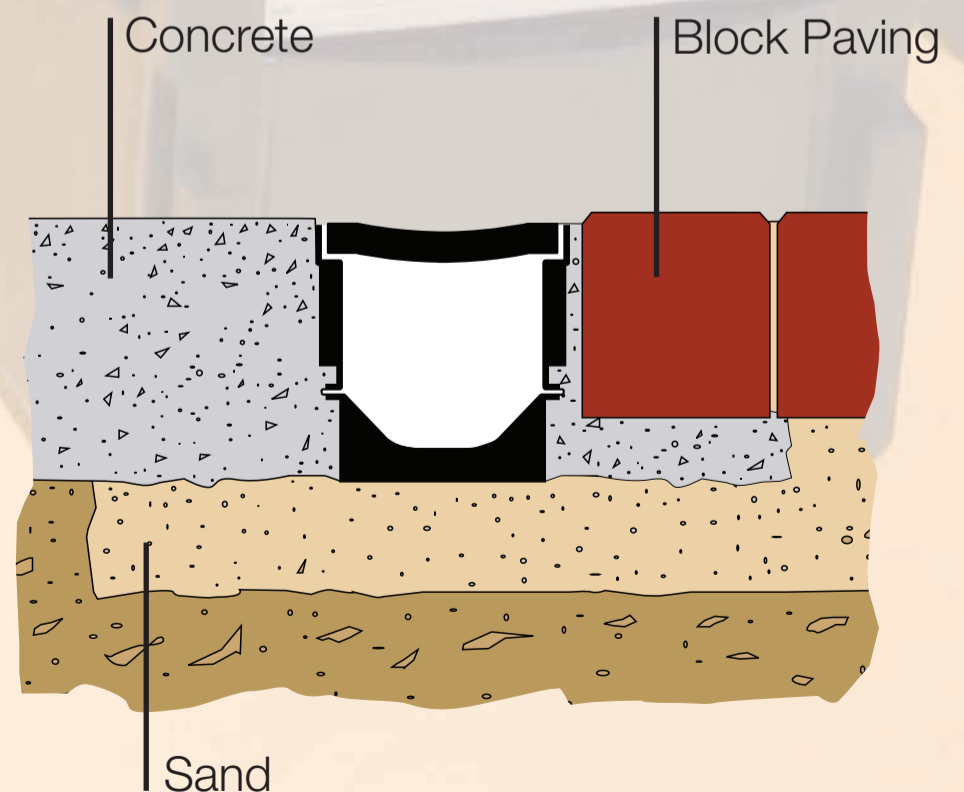
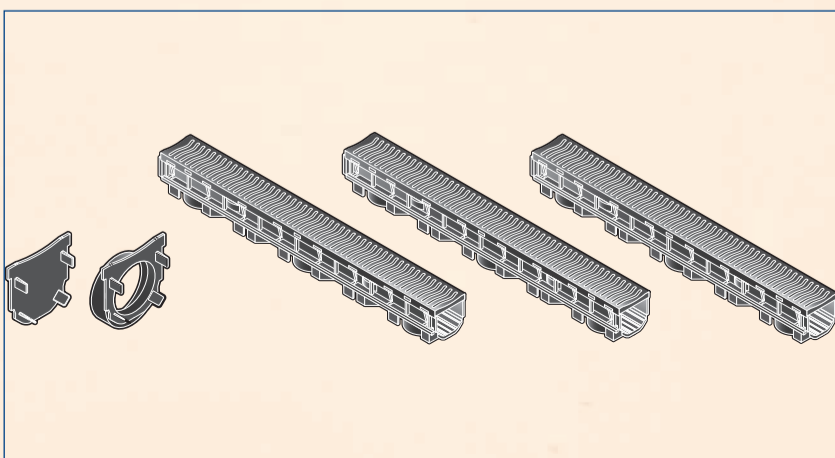

D750: Garage Pack  
(3 x 1 length, End Cap and Outlet)